

Pump system Aquapump Retrofit Duo, GTF 600,submersible pressure switch

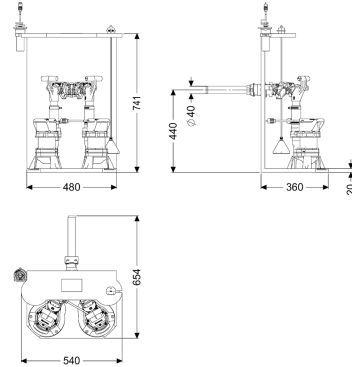

Article information

Item no.: 8744000
 GTIN: 4026092103302
 Price group: 60

Description

The pump system for installation in existing collection tanks for wastewater without sewage is equipped with two submersible pumps, a backflow preventer and a manual locking device. The polymer profile (PE) is used to mount and fix the pumping station. Quick-release closures enable easy removal of the pumps. The station is controlled by a user-friendly control unit, which is optionally integrated in the building management system via a potential-free contact, or alarm and collective fault messages can be output via a GSM interface.

Variant

Type of system:	duo pump
Pump control:	Control unit
Backflow preventer:	integrated
Pressure pipe connection:	horizontal

General characteristics

Standard:	EN 12050-2
Type of wastewater:	without sewage
Installation situation:	installation in on-site collecting tank
Delivery state:	Modular set for assembly on site
System type:	Duo

Dimensions

Net weight:	24 kg
Gross weight:	24 kg

Packaging dimension:	length
Packaging dimension:	width
Packaging dimension:	height
Tank/drain body	
Pressure pipe connection (DN):	32
Pressure pipe connection (OD):	40 mm
Pumping device	
Pump:	GTF 600
Number of pumps:	2
Weight, pump:	6 kg
Connection type:	Schuko (earthed contact) 2-pin
Operating voltage:	230 V
Mains frequency:	50 Hz
Rated current:	2,9 A
Protection class:	I
Insulation class:	F
Cos phi - power factor:	0,92
Protection class (pump):	IP 68 (3m)
Temperature monitoring:	integrated
Max. temperature (permanent) of conveyed material:	40 °C
Max. pumping capacity:	12 m ³ /h
Max. pumping height:	8 m
Speed:	2750 U/min
Power P1:	0,65 kW
Power P2:	0,4 kW
Operating mode:	S1
Type of pump connection cable:	H07RN-F 3G 1.5 mm ²
Impeller type:	Multi-vane impeller
Free passage:	30 mm
Type of fuse required (electrical protection):	C 16 A
Length of mains cable for pump:	10 m
Control	
Control unit:	Comfort
Motor protection switch:	yes
Alarm sensor:	optical probe
Level measurement instrument:	Submersible pressure switch
Type of level measurement:	pneumatic
Protection class control unit:	IP 54
Mains frequency:	50 Hz
Operating voltage:	230 V
Connection type:	Schuko (earthed contact) 2-pin
Length of mains cable for control unit:	1,4 m
Potential-free contact:	optional
GSM interface:	yes
USB interface:	yes
Log book function:	yes

Multi-line display:	yes
Battery buffering:	yes
Self-diagnosis system (SDS):	yes
Type of fuse required (electrical protection):	C 16 A