

Pumping station Aquapump XXL AX Duo, STZ 5200-S1

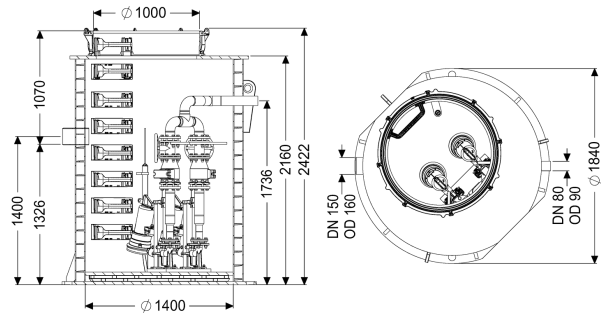

Article information

Item no.: 8743040
 GTIN: 4026092078082
 Price group: 60

Description

Variant

Note on installation depth:	in combination with a chamber module
Type of system:	duo pump
Shut-off valve:	Shut-off valve made of cast iron
Passage seal for conduit pipe (DN):	100
Access steps:	yes
Passage seal for ventilation pipe (DN):	100
Installation:	Wet installation
Pump control:	Control unit
Backflow preventer:	integrated
Pressure pipe connection:	horizontal
Chamber system:	Twin walled re-enforced pipe chamber

General characteristics

Colour:	black
Standard:	EN 12050-1
Type of wastewater:	with sewage
Installation situation:	underground installation
Delivery state:	Pre-mounted for final assembly on site (pumps and sensor system must be fitted on site and control unit must be connected)
System type:	Duo
ATEX:	yes

Dimensions

Net weight:	674,9 kg
Gross weight:	742,9 kg
Groundwater resistant from lower edge of base section:	3000 mm
Length:	1880 mm
Width:	1880 mm
Height:	2440 mm
Packaging dimension:	length
Packaging dimension:	width
Packaging dimension:	height

Tank/drain body

Pressure pipe connection (DN):	80
Pressure pipe connection (OD):	90 mm
Distance from centre of outlet pipe to tank bottom:	1735 mm
Distance pipe bottom inlet to tank bottom:	1320 mm
Distance from centre of inlet pipe to tank bottom:	1400 mm
Distance from inlet pipe invert to top of tank:	1090 mm
Inlet nominal size (OD):	160 mm
Inlet nominal size (DN):	150 mm
Number of inlets:	1
Clear width of tank (LW):	1600 mm
Clear width of entry (LW):	1000 mm
Pumping volume:	800 l

Pumping device

Pump:	STZ 5200
Number of pumps:	2
Weight, pump:	56 kg
Connection type:	Direct connection
Rated current:	8,7 A
Protection class:	I
Insulation class:	H
Cos phi - power factor:	0,89
Protection class (pump):	IP 68 (20m)
Temperature monitoring:	integrated
Max. temperature (permanent) of conveyed material:	40 °C
Max. pumping capacity:	21,3 m ³ /h
Max. pumping height:	52 m
Speed:	2840 U/min
Power P1:	5,2 kW
Power P2:	4,4 kW
Operating mode:	S1
Type of pump connection cable:	H07RN8-F PLU 10G 1.5 mm ²
Impeller type:	Macerator
Length of mains cable for pump:	10 m

Control	
Control unit:	Comfort Plus
Motor protection switch:	yes
Alarm sensor:	Level sensor
Level measurement instrument:	Level sensor
Type of level measurement:	hydrostatic
Protection class control unit:	IP 54
Mains frequency:	50 Hz
Operating voltage:	400 V
Connection type:	Direct connection
Potential-free contact:	yes
GSM interface:	yes
USB interface:	yes
Log book function:	yes
Multi-line display:	yes
Battery buffering:	yes
Self-diagnosis system (SDS):	yes