

Lifting station Minilift L GTF 1000, free-standing set-up

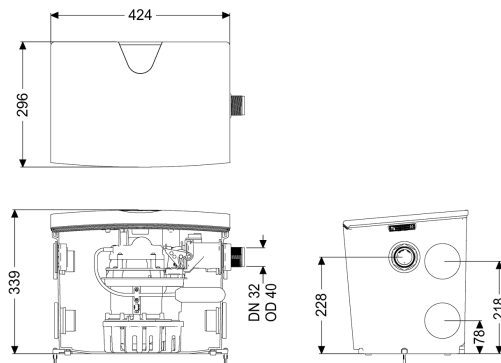

Article information

Item no.: 28563
 GTIN: 4026092097014
 Price group: 20

Advantages

- Resistant to hot water
- Variable top and side inlets
- Easy tool-free maintenance

Description

The plug-in ready Minilift L small lifting station is suitable for the disposal of domestic wastewater and ideal for connecting a shower, bathtub, washbasin, sink, dishwasher or washing machine.

The submersible pump with float switch can be removed easily with the help of one-handed closures. The collection tank made of polymer has an open pump tank and is resistant to aggressive wastewater. Due to its numerous inlets (4x DN 50 horizontal, 1x DN 40 vertical) and adaptable outlets

The system offers flexible and simple options for on-site installation.

- Resistance to hot water and brine
- Discharge side backflow preventer integrated in the factory
- Powerful pump with multi-vane vortex impeller for maximum operating safety
- Tool-free maintenance

Variant

Type of system:	Single unit
Pump control:	Float switch
Backflow preventer:	integrated
Pressure pipe connection:	horizontal

General characteristics

Colour:	white
Standard:	EN 12050-2
Type of wastewater:	without sewage

Installation situation:	free-standing installation
Delivery state:	plug-in ready
Dimensions	
Net weight:	16 kg
Gross weight:	16,35 kg
Length:	425 mm
Width:	300 mm
Height:	340 mm
Packaging dimension:	length
Packaging dimension:	width
Packaging dimension:	height
Tank/drain body	
Pressure pipe connection (DN):	32
Pressure pipe connection (OD):	40 mm
Number of inlets:	5
Pumping volume:	7 l
Tank volume:	30 l
Inlet vertical (DN):	40
Inlet horizontal (DN):	50
Pumping device	
Pump:	GTF 1000
Number of pumps:	1
Weight, pump:	10 kg
Connection type:	Schuko (earthed contact) 2-pin
Rated current:	5,6 A
Protection class:	I
Protection class (pump):	IP 68 (3m)
Temperature monitoring:	integrated
Max. temperature (permanent) of conveyed material:	40 °C
Hot water resistance for a short time (2 min):	80 °C
Max. pumping capacity:	14,5 m ³ /h
Max. pumping height:	10 m
Speed:	2800 U/min
Power P1:	1,27 kW
Power P2:	0,73 kW
Operating mode:	S3 - 50 %
Type of fuse required (electrical protection):	C 16 A
Type of pump connection cable:	H07RN-F 3G 1.5 mm ²
Impeller type:	Multi-vane impeller
Free passage:	10 mm
Length of mains cable for pump:	5 m
Control	
Level measurement instrument:	Float switch
Type of level measurement:	mechanical
Mains frequency:	50 Hz

Operating voltage:	230 V
Connection type:	Schuko (earthed contact) 2-pin
Type of fuse required (electrical protection):	C 16 A