

Aqualift S Compact lift stat. Tronic, GTF 1200, res., Floor slab, bl.

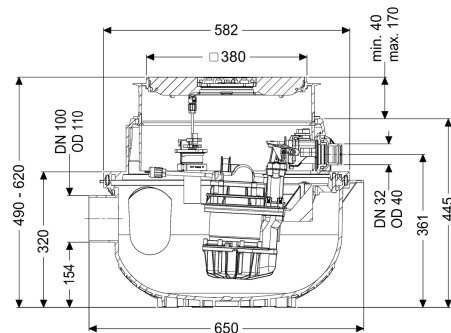

Article information

Item no.: 281250SC
 GTIN: 4026092094884
 Price group: 20

Advantages

- Space-saving due to installation in floor slab with integrated drainage function
- Easy retrofitting from Mono to Duo possible
- Quiet operation, as the pump installation does not cause any structure-borne sound emissions.

Description

The ready to plug in lifting station for faecal-free wastewater is equipped with one or two submersible pumps and a backflow preventer. The collection tank made of permanently resistant polymer (PE) has an open pump tank. One-handed closures enable easy removal of the integrated components. The system for installation in the floor slab is preassembled for final installation on site.

Variant

Type of system:

Single unit

Resistant:

Resistant to saline media, wastewater from water softening systems and wastewater containing condensate from heating systems

Pump control:

Control unit

Backflow preventer:

integrated

General characteristics

Colour:

black

Standard:

EN 12050-2

Type of wastewater:

without sewage

Installation situation:

floor slab installation

Delivery state:

Installation-ready (connection parts must be connected on site)

System type:

Tronic

Dimensions	
Net weight:	18,27 kg
Gross weight:	19,77 kg
Groundwater resistant from lower edge of base section:	3000 mm
Installation depth:	490 - 620 mm
Type of height adjustability:	vertically adjustable upper section
Length:	617 mm
Width:	585 mm
Packaging dimension:	length
Packaging dimension:	width
Packaging dimension:	height
Tank/drain body	
Pressure pipe connection (DN):	32
Pressure pipe connection (OD):	40 mm
Inlet nominal size (DN):	100 mm
Pumping volume:	20 l
Tank volume:	65 l
Coverage features	
Type of cover:	Cover plate
Cover material:	Polymer
Colour of cover:	black
Width of cover:	366 mm
Length of cover:	366 mm
Drainage function:	yes
Locking:	Lock & Lift
Load class:	K 3 (EN 1253-1)
Pumping device	
Pump:	GTF 1200 resistant
Number of pumps:	1
Weight, pump:	10 kg
Connection type:	coded plug
Rated current:	6,2 A
Protection class:	I
Insulation class:	F
Protection class (pump):	IP 68 (3m)
Max. temperature (permanent) of conveyed material:	40 °C
Hot water resistance for a short time (2 min):	80 °C
Max. pumping capacity:	15,5 m ³ /h
Max. pumping height:	9 m
Speed:	2650 U/min
Power P1:	1,4 kW
Power P2:	0,84 kW
Operating mode:	S1
Type of fuse required (electrical protection):	C 16 A

Type of pump connection cable:	H07RN-F 3G 1.5 mm ²
Impeller type:	Multi-vane impeller
Free passage:	30 mm
Length of mains cable for pump:	5 m
Control	
Control unit:	Comfort
Control unit function:	With alarm message
Motor protection switch:	yes
Alarm sensor:	optical probe
Level measurement instrument:	Immersion pipe
Type of level measurement:	pneumatic
Protection class control unit:	IP 54
Mains frequency:	50 Hz
Operating voltage:	230 V
Connection type:	coded plug
Length of mains cable for control unit:	1,4 m
Potential-free contact:	optional
GSM interface:	yes
USB interface:	yes
Log book function:	yes
Multi-line display:	yes
Battery buffering:	yes
Self-diagnosis system (SDS):	yes
Warning equipment version:	acoustic and optical signal
Type of fuse required (electrical protection):	C 16 A