

Aqualift F XL, 450 L lift. stat. Duo, SPF 4500-S1

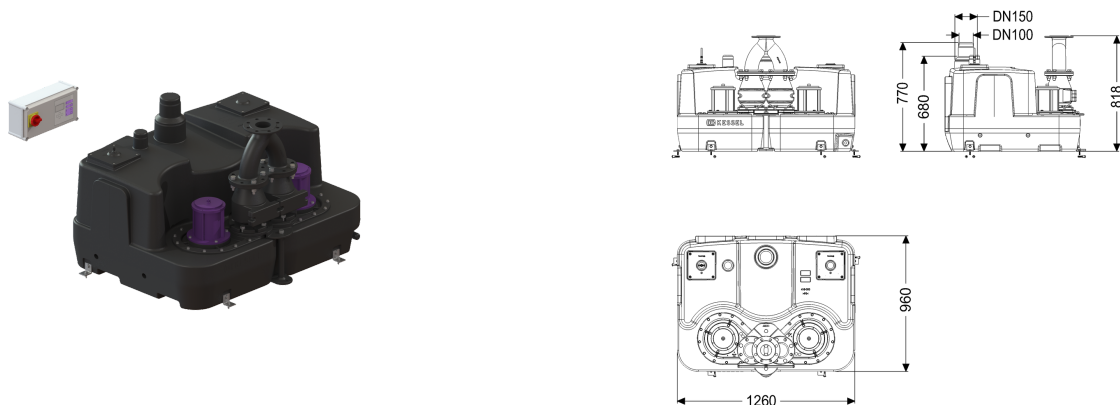

Article information

Item no.: 11126
 GTIN: 4026092057933
 Price group: 50

Advantages

- Different performance classes available
- Pressure sensor for reliable pneumatic level measurement
- Maximum operating reliability due to intelligent control unit (Duo)

Description

The lifting station for faecal and faecal-free wastewater is equipped with one or two submersible pumps and a backflow preventer. The collection tank made of permanently resistant polymer (PE) offers universal connection options and has a screwed access cover.

Variant

Type of system:	duo pump
Shut-off valve:	without shut-off valve
Pressure pipe connection:	vertical

General characteristics

Colour:	black
Standard:	EN 12050-1
Type of wastewater:	with sewage
Installation situation:	free-standing installation
System type:	Duo

Dimensions

Net weight:	205 kg
Gross weight:	225 kg
Packaging dimension:	length
Packaging dimension:	width
Packaging dimension:	height

Tank/drain body	
Tank volume:	450 l
Pumping device	
Pump:	SPF 4500
Number of pumps:	2
Length of mains cable for pump:	5 m
Operating mode:	S1
Type of fuse required (electrical protection):	3 x C 25 A
Impeller type:	Multi-vane impeller
Free passage:	40 mm
Control	
Control unit:	Comfort
Level measurement instrument:	Immersion pipe
Type of level measurement:	pneumatic
Mains frequency:	50 Hz
Operating voltage:	400 V